

MORGO®

TRIUMPH PRE-UNIT ROTARY OIL PUMP



08/04/1998

FITTING INSTRUCTIONS

Manufactured By

AUTOVALUES ENGINEERING

Albion Road, Idle, Bradford, BD10 9LZ, England

Tel. +44 (0) 1274-614424 Fax. +44 (0) 1274-611560

Web:- <http://www.morgo.co.uk>

Email:- sales@morgo.co.uk

(2)

PLEASE READ CAREFULLY BEFORE PROCEEDING

With respect to the more enlightened, some aspects of these instructions may appear elementary, but it must be pointed out that some of our customers have never seen the inside of a PRE-UNIT construction Triumph twin.

WE STRONGLY RECOMMEND WITHOUT EXCEPTION EVERYONE TO READ THESE INSTRUCTIONS CAREFULLY.

- 1.** Drain oil from oil tank.
- 2.** Remove the timing cover fixing screws (noting the screws are of different lengths). Remove cover using a rubber hammer, tapping round the sides of the cover gently. Under no circumstance drive screwdrivers or such between the mating faces as this will destroy the re-sealing of the timing cover.
- 3.** The old oil pump is held in place by two nuts with cone locking washers. Remove the nuts and washers. Slide pump and gasket off the studs. Screw the two nuts onto one stud and lock them together.
i.e. turn inside nut anticlockwise and outside nut clockwise. With spanner on inside, turn nut anticlockwise: stud will now unscrew. Repeat for second stud.

NOTE

The old studs will not be needed to fit the new Morgo pump

- 4.** Remove pump drive nut from rear cam shaft. Turn clockwise to remove. To prevent the shaft rotating, place gearbox in top gear and apply rear brake.
- 5.** Check the fixing screws supplied with your new pump are the correct thread ie. Cycle. Your engine may not be the original one, fitted to your machine, (Re-threading may have taken place) so year and model are no guide in such a situation.

Fitting New Morgo Super Pump

Very important drive nut to pump body clearance See Fig. 1

1. Fit slotted drive nut onto rear cam shaft and tighten up, holding again with brake. Push the timing gear towards the engine casing. Fit pump with gasket but without drive insert to engine place feeler gauge down the access slot to determine the clearance .005" TO .015" is recommended 4 drive nut shim washers are supplied with the pump kit .005" .010" .015" .020" the computation of same should give the correct clearance, if the clearance is found to be correct move onto Step 2

PLEASE NOTE

Some after market timing gears are under size on thickness, this reduces the pump drive location and can cause premature wear to the pump drive, this situation can be established by the above feeler gauge clearance procedure. Shim washers are provided to adjust drive nut stand off. This is accomplished by placing the shim washers between the timing gear and the drive nut. (See Fig. 1)

2. Holding the pump horizontal with the feed holes uppermost pump clean engine oil into the 5 transfer holes with a pump type oil can or similar fitted with a outlet nozzle that is a good fit in the pump body holes. This pressure injection of oil is very important to make sure the pump is fully primed and not air locked. It is also good practice to pump oil into the holes in the crankcase all the way back to the oil tank and down the scavenge pickup tube, you cannot over fill with oil. The scavenge side of the pump will remove any excess oil you pump into the engine. Also fill the crankshaft by pumping oil into the end of the shaft, this promotes a more immediate feed and scavenge of the engine. After the first start up of the engine the pump will stay primed unless the oil feed pipes are removed for any reason, in which case the pump will have to be re-primed (See 7 Below). Finally turn the pump, stopping so that when shaft insert is fitted it will match the position of the drive nut.

3. Put a small dab of grease in the drive slot in the pump shaft to hold the floating insert in place, offer the pump without gasket and screws into the drive nut slot, moving the pump in a rotary backward and forward movement. When the floating insert engages in the drive slot look down the screw holes and line up with the holes in engine casing. This will make the fixing screws easier to locate on assembly.

(4)

IMPORTANT

now pump oil into the 5 holes in the pump once again to make sure the pump is still fully primed. The pump will not pump oil if it is not full of oil or is air locked. Lay the pump down driving side uppermost in a clean place.

4. with a solvent, thoroughly clean the two threaded pump fixing holes in the engine casing. Wash the two socket headed screws supplied and allow to dry.

5. Put the two screws in the holes in pump body and put gasket over screw threads. (Critical: make sure holes in gasket line up with holes in pump)

6. Put a small quantity of screw lock on each screw and in the first two threads of the two threaded holes in the casing. **DO NOT!** put an excess of screw lock in the holes, or the screws can hydraulically burst the engine casing. Place pump in position, screw in the two screws each one a small amount at a time, until both screws centralise the pump, then nip up tightly. Check the camshaft has still got end float.

7. Now fill oil tank with oil, remove centre priming vent bleed screw with hexagon head and screwdriver slot and allow air and oil to escape until all air bubbles stop and oil only escapes, (it may take a few seconds for the oil to drain down from the oil tank) after a generous amount of oil has escaped replace bleed screw and lock tab washer, lock the screw up tightly and secure with lock tab. The pump is now fully primed.

8. On some engines the timing cover has been modified to give slightly more clearance for the larger oil pumps. Check if the cover fouls the left hand side of the pump. Also check that there is no damage on the two mating cover faces. Place the cover on the engine, if the cover sits flush up to the engine face no modification is needed. Go to step 10. If a gap can be seen we recommend the following procedure.

9. Place a piece of plasticine about 25mm square and 12mm thick inside the cover just under the second boss down on the right hand side looking into the cover. Put the cover back on, press fully on. Remove cover and the contact area will now be revealed. Carefully remove a small amount of material with a rotary burr and electric drill or similar, until a clearance is achieved.

10. From now on re-assembly is fully covered in the Triumph manual, or alternatively reverse the dismantling procedure.

PRESSURE RELIEF VALVE

(5)

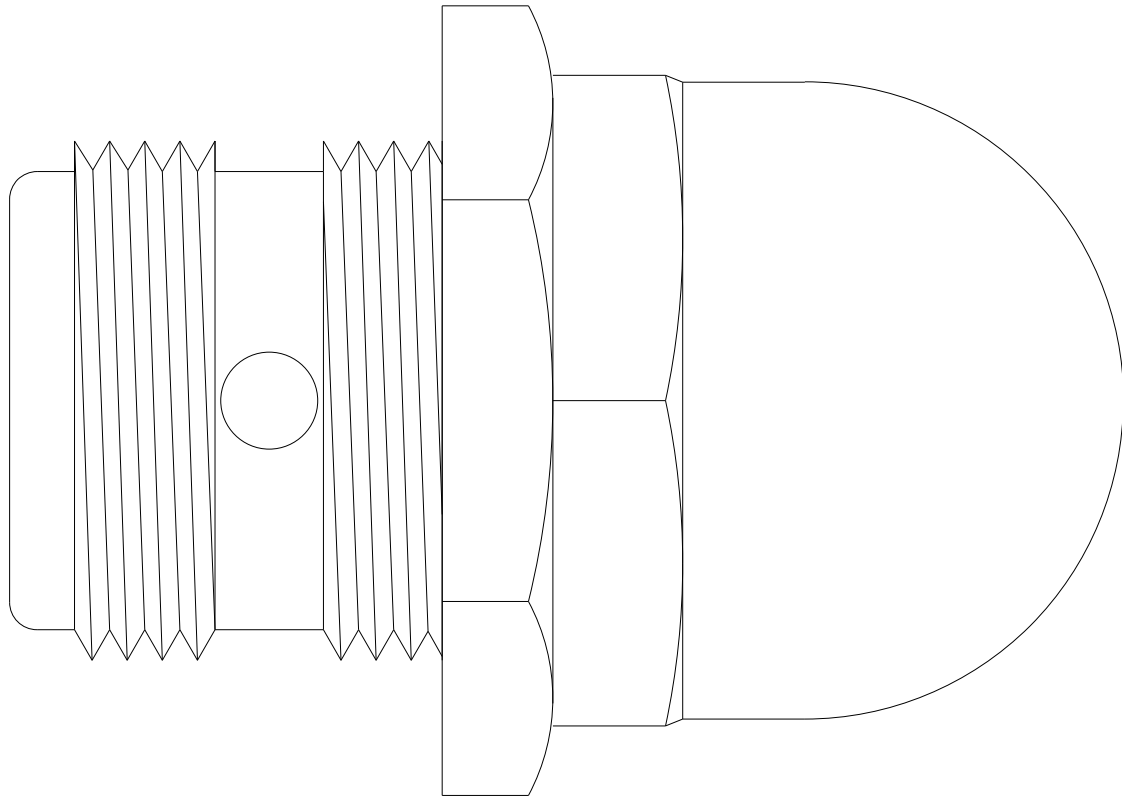

11. Important to rider's likely to ride at high revs for long periods it is essential to remove the crankcase pressure relief valve and drill extra holes (2 holes minimum 4 holes preferred, some older valves only have one hole) to allow a more free flow of excess oil back to the crankcase. The reason for this is, with the new morgo super oil pump being capable of a greater oil delivery, it is possible for excess oil to build up and not being able to escape through the holes in the valve body, will distort the crankshaft timing cover oil seal, resulting in a drop in oil pressure until the seal is replaced. Note it is very important after drilling extra holes in the P.R.V. that the drilling burrs are carefully removed from the internal piston bore. To make sure that the piston still has free movement all the way down its travel, to the shut off seating face.

The P.R.V. can be a source of problems, the after market ones in particular, some of which are not made to the correct tolerances. Allowing oil to pass between the 7/8" diameter thread and the engine casing through the P.R.V. body causing pressure build up at the spring end of the piston and hydraulicing the valve shut, making the P.R.V. unable to control the pressure correctly. This situation has occurred many times in the past with high performance engines fitted with all types of plunger type oil pumps. The situation is brought to light more readily with the rotary pump because of the extra oil flow. It is sad to say that in many cases an old P.R.V. in good condition, with extra holes drilled, is a better solution to the problem than incorrectly manufactured ones.

(6)

12. The oil tank scavenge return pipe **must not be over restricted** at the oil tank end. The reason for this is the Morgo Super Pump has a 3 pints per minute feed capability and if the oil is prevented from getting back to the oil tank effectively, and if a much larger quantity of oil than normal is retained in the engine as a result, the engine may give the impression of wet sumping when the engine is cold. **This is very unlikely but is worth pointing out.**

IMPORTANT

Before starting the engine remove spark plugs and oil pressure switch, then kick the engine over until oil appears out of the oil pressure switch hole, this is to make sure you have got oil pressure on machines not fitted with an oil pressure gauge.

NOTE

13. Do not be fooled into thinking you have oil pressure just because oil is returning from the scavenge outlet tube this oil could be the residue from previous running with the old pump and not new oil delivered from the new rotary pump.

It will also be noted that when the oil is cold, the oil level in the oil tank can reduce but will return to its normal level on warming up after only a few minutes running. The reason for this is, the new pump having a larger delivery than the old plunger type pumps, resulting in more thick oil being delivered back to the crankcase via the pressure relief valve. Because the oil is thick the crankshaft picks up and carries a higher proportion of this extra waste oil than normal around itself and centrifugal deposits the oil on the crankcase inner surfaces. Also a greater amount of oil is held in the timing cover, until the oil warms up. As soon as the engine warms up only marginally, the oil drains to the bottom freely hence the oil level in the tank returning to normal.

(The above can give the impression of wet sumping)

14. Whilst we are not suggesting for one minute that oil filter units should not be fitted in the scavenge return, it must be pointed out they do offer a partial restriction particularly when the oil is cold and more so when due for changing. Therefore it is recommended units with a by-pass safety relief valve facility should be fitted.

IMPORTANT

OIL CHANGING

15. When engines are totally drained of oil ie. Oil tank and crankcase etc. It is advisable to pour approximately 1/4 pint of oil into the crankcase via the rocker box. The oil will drain down in a very short time. This makes oil immediately available for the scavenge return to feed the rockers.

It must be remembered the Triumph twins have not had the benefit of such a generous oil supply in the past and have to be adjusted in some cases accordingly, especially after past experimenting by previous owners attempting to make the best of a poor oil supply to the ROCKERS. Some owners in the past have restricted scavenge oil return outlet at the oil tank outlet to gain more oil to the rockers, you will find the oil return with the super pump is more effective.

NOTE

Your pump has run at 7,500 RPM on test, your engine would have to run at 15,000 RPM to equal that.

Important: Oil in frame models. When doing oil change, to help prevent oil draining down from pump, place tourniquet on bottom flexible feed pipe until tank is re-filled.

IMPORTANT: See note 13

The golden rule with the MORGO SUPER PUMP is, if the oil is there and the pump is primed the pump will pump it.

**Remember advice is always at
the end of the Phone , Fax or Email.
MORGO.**

IMPORTANT

CLEARANCE BETWEEN NUT AND DRIVE SHAFT .005" TO .015"

FIG. 2

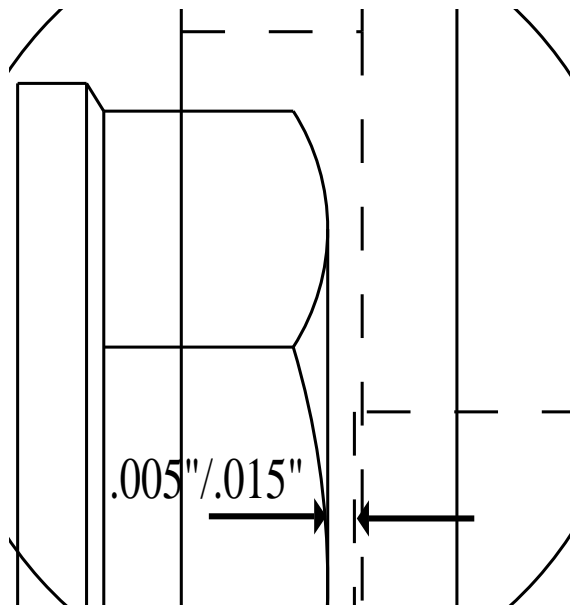
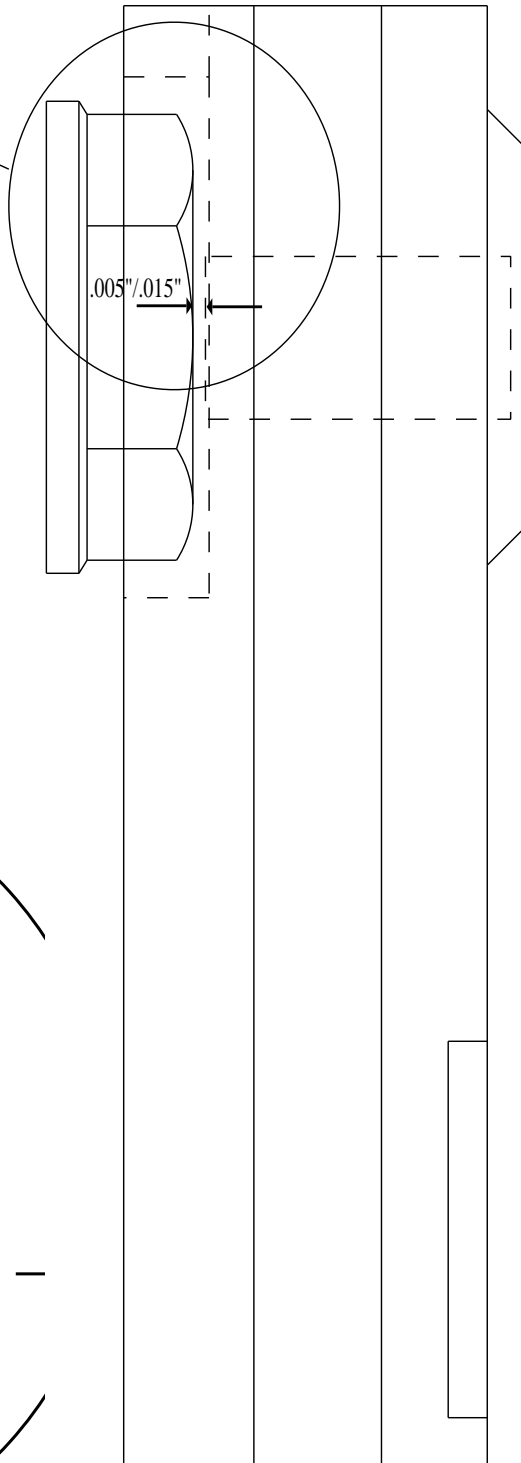

FIG. 2

FIG. 1